

P120

- **Linear steady state characteristics**
Lineare Kennlinie
- **Integrated hydraulic accumulator**
Integrierter Druckspeicher
- **Safe to run dry (liquid)**
Trockenlaufsicher (Flüssigkeit)
- **Dry self-priming up to 2 meters depth, then self-priming up to 4 meters depth**
Trockenansaugend bis 2 Meter Tiefe, danach selbstansaugend bis 4 Meter Tiefe
- **Liquid fertiliser-proof (UAN)**
Flüssigdüngerfest (AHL)

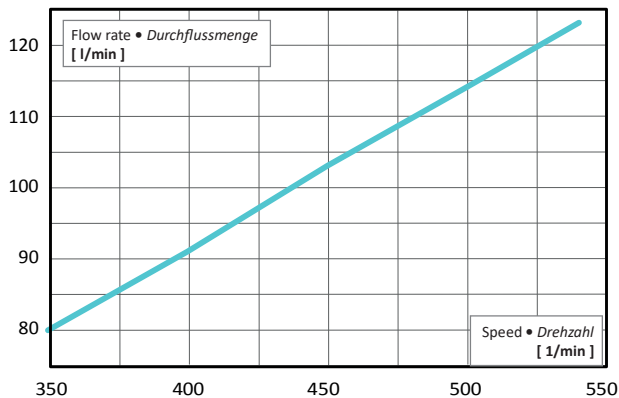

Basic Parameters Eckdaten		
Nominal speed [rpm]	Nenn Drehzahl [U/min]	540
Speed range [rpm]	Drehzahlbereich [U/min]	450 — 600
Permanent pressure [bar]	Druck, auf Dauer [bar]	max. 15
Short-term pressure [bar]	Druck, kurzzeitig [bar]	max. 20
Spline shaft	Zapfwelle	DIN 9611 ISO 500

Lubrication: Oil bath	Schmierung: Ölbad
Materials: Cast aluminium, partially anodised, stainless steel, NBR seals, POM	Material: Aluminiumguss, teilweise eloxiert, Edelstahl, NBR-Dichtungen, POM

- Options:
Desmopan® Diaphragms
Hydraulic drive
- Sonderausführungen:
Desmopan® Membranen
Hydromotor

Specifications in mm
Angaben in mm

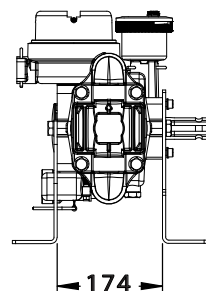
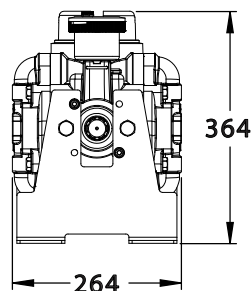

Capacity at 5 bar	Literleistung bei 5 bar	120 l/min
Article no.	Artikel-Nr.	83035*
Working diaphragms	Arbeitsmembrane	2 x NBR
Accumulator diaphragms	Druckspeichermembrane	1 x NBR
Inlet-Ø suction	Einlass-Ø Saugseite	AS40
Outlet-Ø pressure	Auslass-Ø Druckseite	AS30
Weight	Gewicht	19 kg

* Setup with bracket and pto protection, including oil filling
* Aufbau mit Halterung und Schutztopf, inkl. Ölfüllung

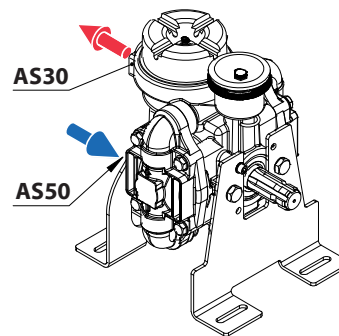

Power Consumption at 540 rpm Leistungsaufnahme bei 540 U/min	5 bar	10 bar	15 bar
	2,2 kW	3,2 kW	4,0 kW